

ROYAL R2S

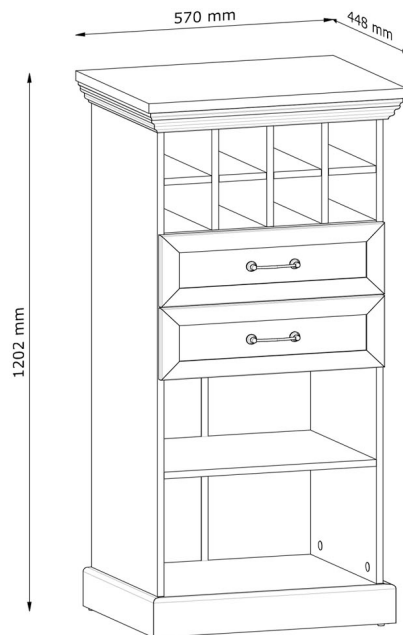

Vážený Zákazníku!

Před montáží nábytku si pečlivě přečtěte následující pokyny PRVKY NESOUČÍ STOPY MONTÁŽE REKLAMOVANÉ PRO MECHANICKÁ POŠKOZENÍ NEBO VADY NEPODLÉHAJÍ REKLAMACI V případě pochybností během montáže nás prosím kontaktujte. Nábytek se sestavuje podle následujících kroků uvedených v příručce. Kódy nalepené na částech nábytku odpovídají kódům v příručce. Pozor! Kolíky nabíjíme do úzké roviny prvku. Pozor! Zadní stěnu nábytku a spodní část zásuvky montujeme po nastavení úhlopříčky (viz obrázek)

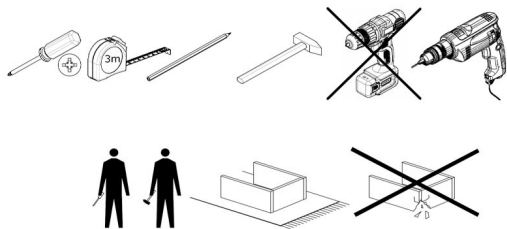
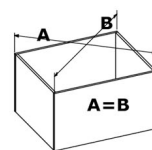

Posledním krokem je umístění nábytku na správné místo a pomocí vodováhy zkontrolování vertikální a horizontální polohy nábytku a nastavení čelních ploch na pantech. Tipy pro péči. Nábytek čistíme pouze prachovou utěrkou (suchou nebo vlhkou)! Nepoužívejte žádné chemické čisticí prostředky! Skleněné prvky prosím čištěte prostředky pro čištění skla, které jsou k dispozici na trhu, a jak je uvedeno na obalu vybraného produktu.

Pozor! Koloristika dekorativní lišty a obvodu nábytku se může mírně lišit od barvy desky. Závísí to na várce produktu. Toto NENÍ základem pro reklamaci.

Pozor! Výrobce nábytku si vyhrazuje právo provádět konstrukční změny nabízeného nábytku, aniž by změnil jeho celkový charakter. Rozměry nábytku se mohou měnit.

VAROVÁNÍ TÝKAJÍCÍ SE SKLOPENÍ!

Tento výrobek musí být trvale připevněn na stěnu pomocí příložených držáků, aby nedošlo ke smrtelnému zranění, kdyby se sklopil. Sada obsahuje pouze šroubky pro upevnění držáků zabraňujících sklopení k výrobku. Ohledně správného typu vrutů/hmoždinek pro daný typ stěny se obraťte na vhodný obchod nebo železářství

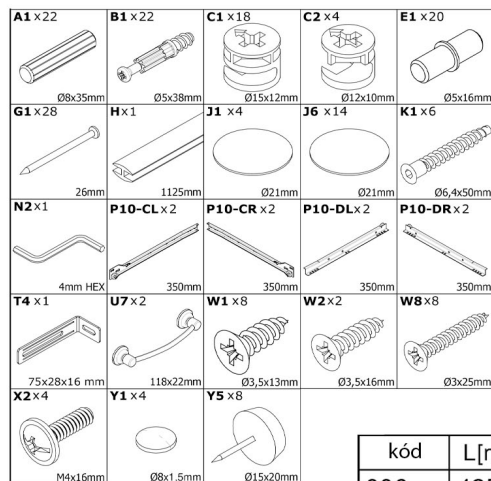
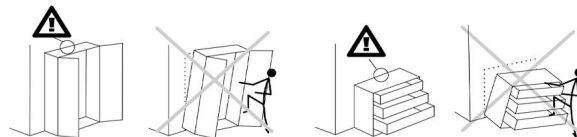

kód	L[mm]	W[mm]	H[mm]	PCS	balíček
006	495	160	18	2	2/3
127	1090	400	15	1	1/3
128	1090	400	15	1	1/3
129	277	400	15	3	1/3
240	537	428,5	86	1	3/3
245	570	445	72	1	3/3
313	105	400	15	4	1/3
314	470	400	15	1	1/3
315	470	400	15	1	1/3
506	432	350	2,5	2	1/3
515	1125	248	2,5	1	1/3
525	1125	248	2,5	1	1/3
W036	1145	100	12	2	1/3

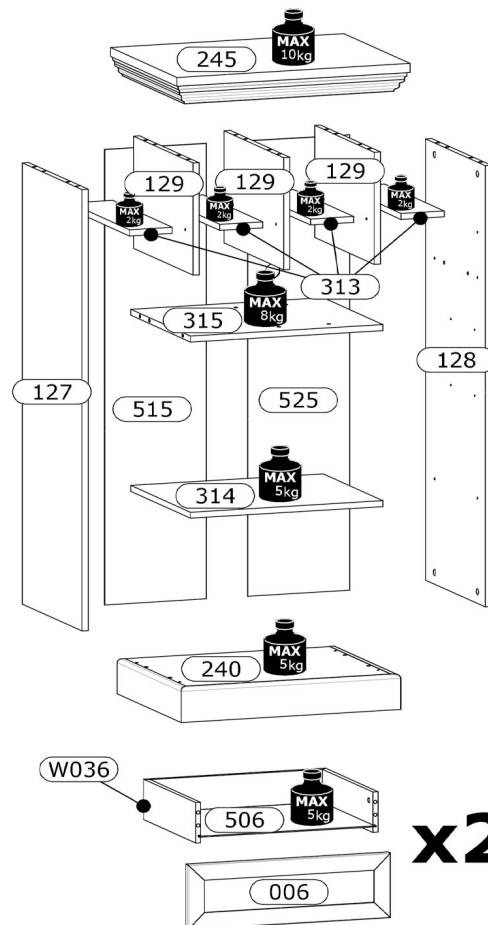

x2

1

B1 x 4
Ø5x38mm

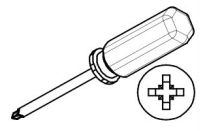
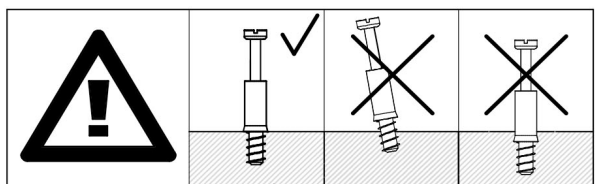
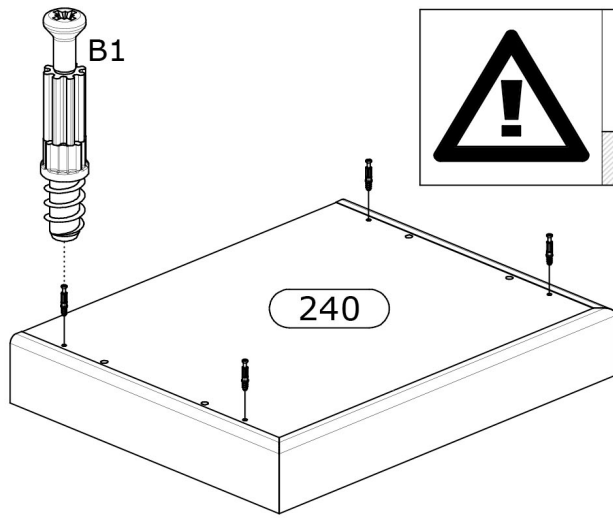

2

B1 x 10
Ø5x38mm

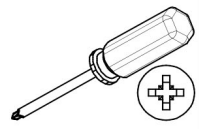
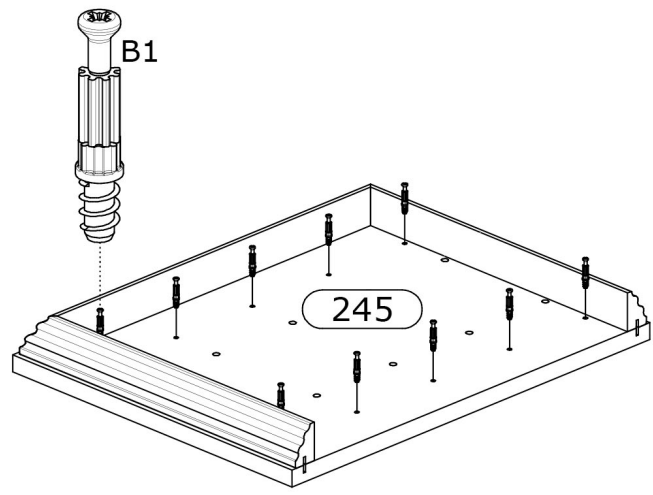

3

A1 x 8
Ø8x35mm

B1 x 4
Ø5x38mm

C1 x 8
Ø15x12mm

E1 x 8
Ø5x16mm

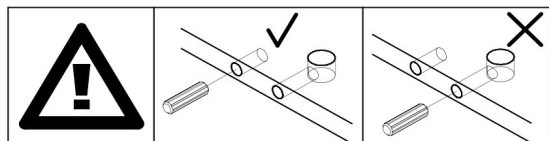
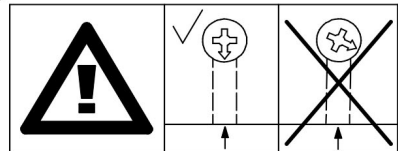
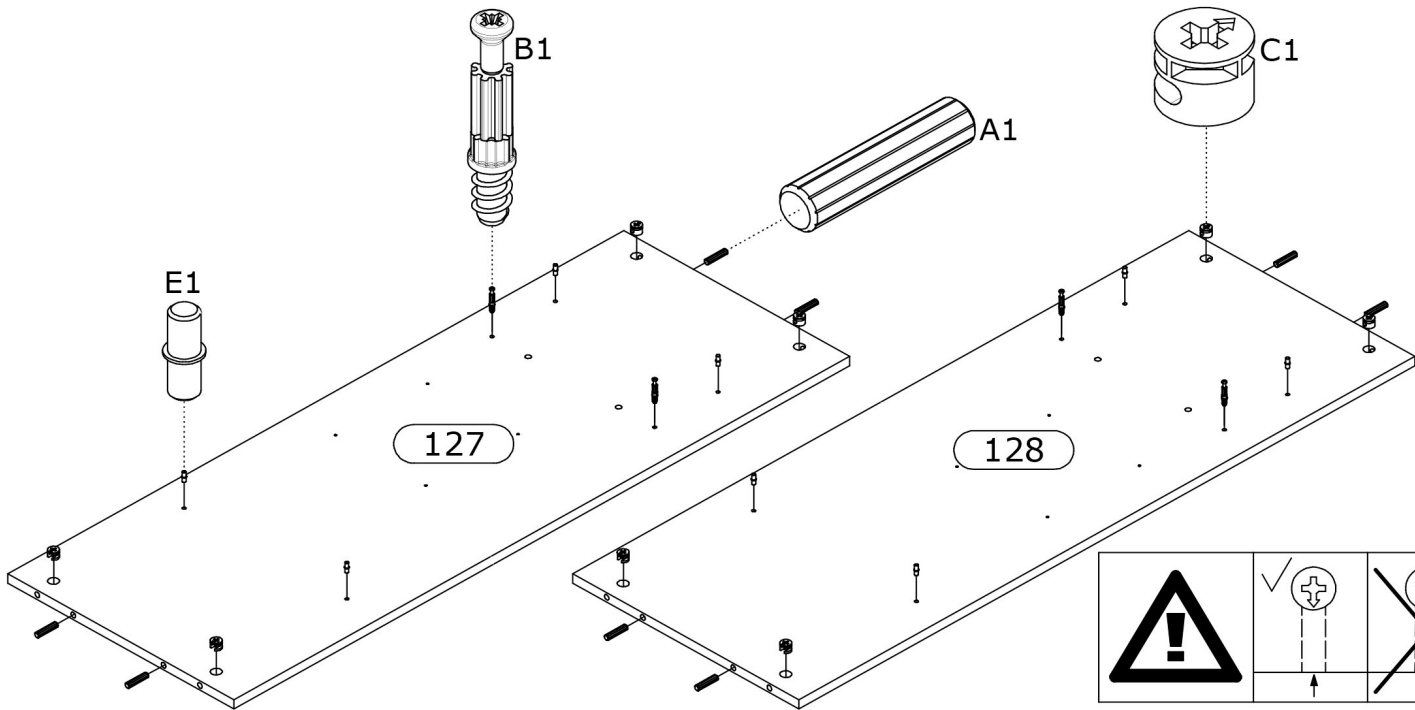
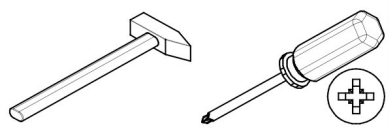

4

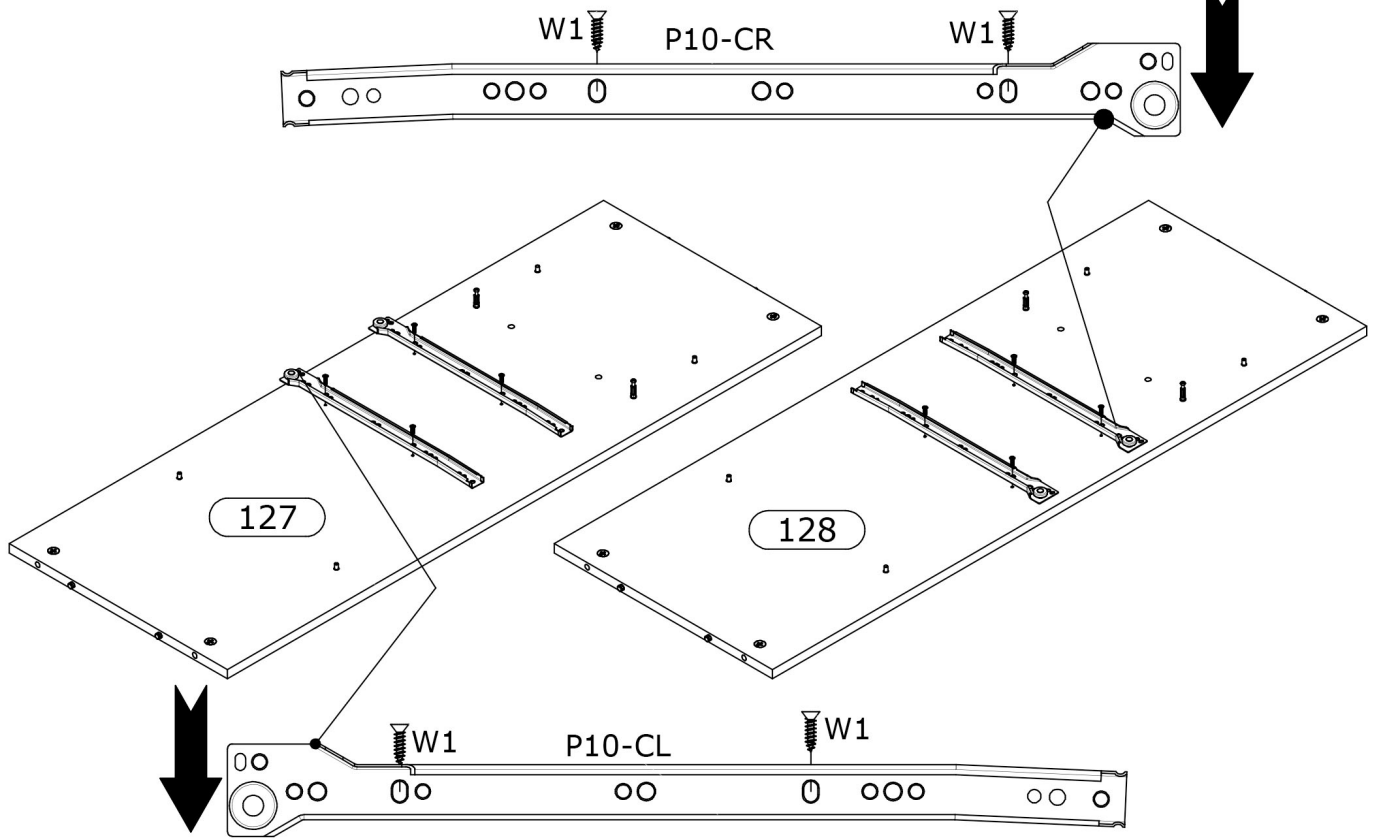
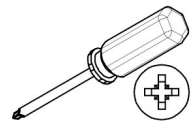
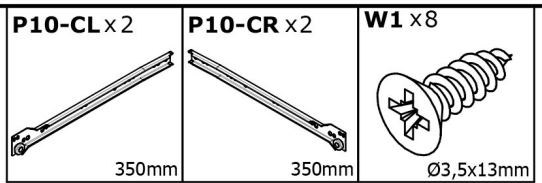

5

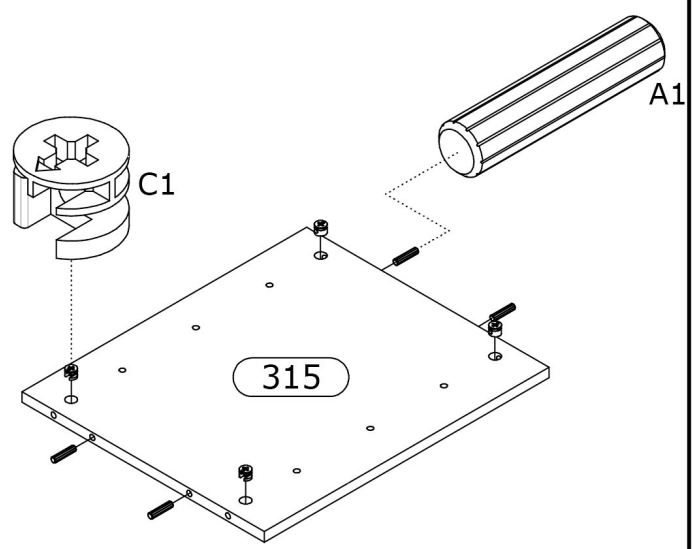
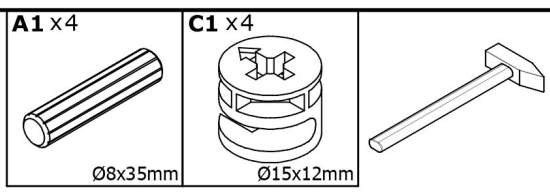

6

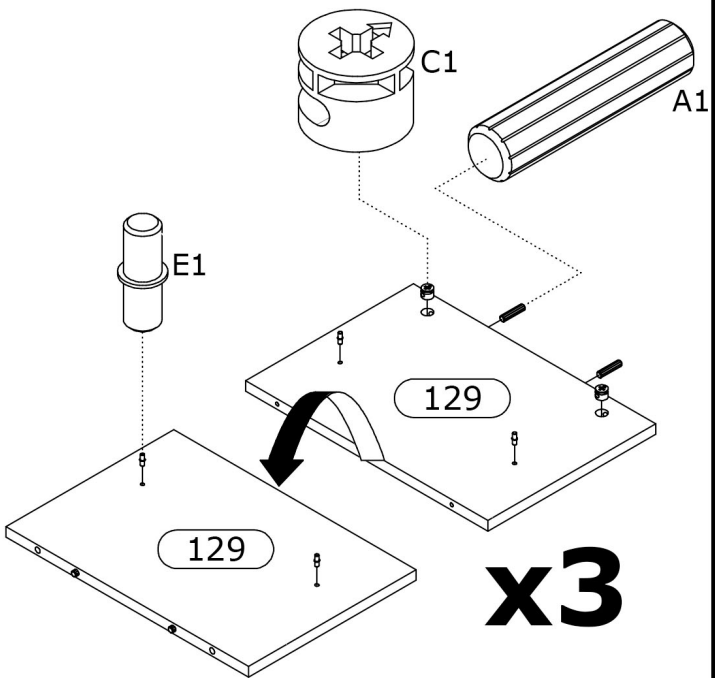
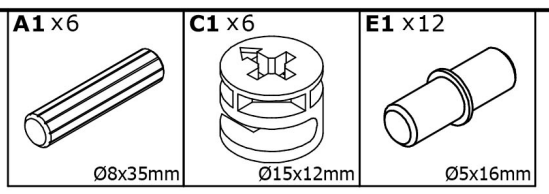

x3

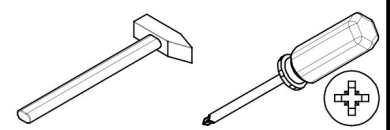

7

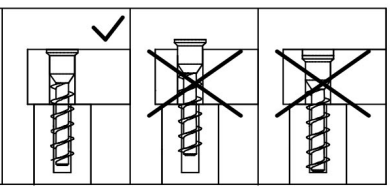
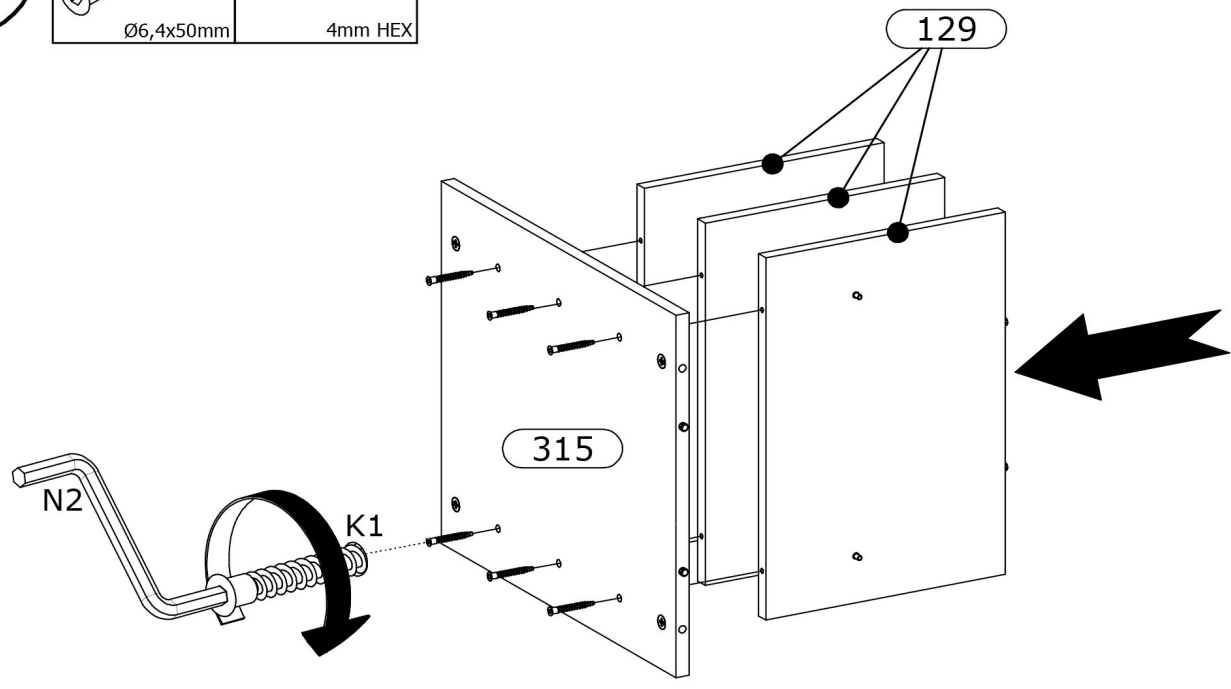
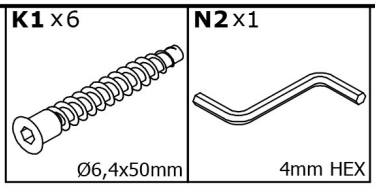

8

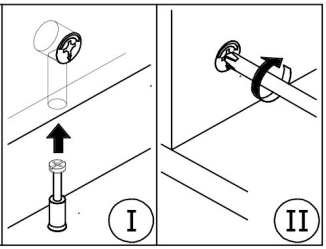
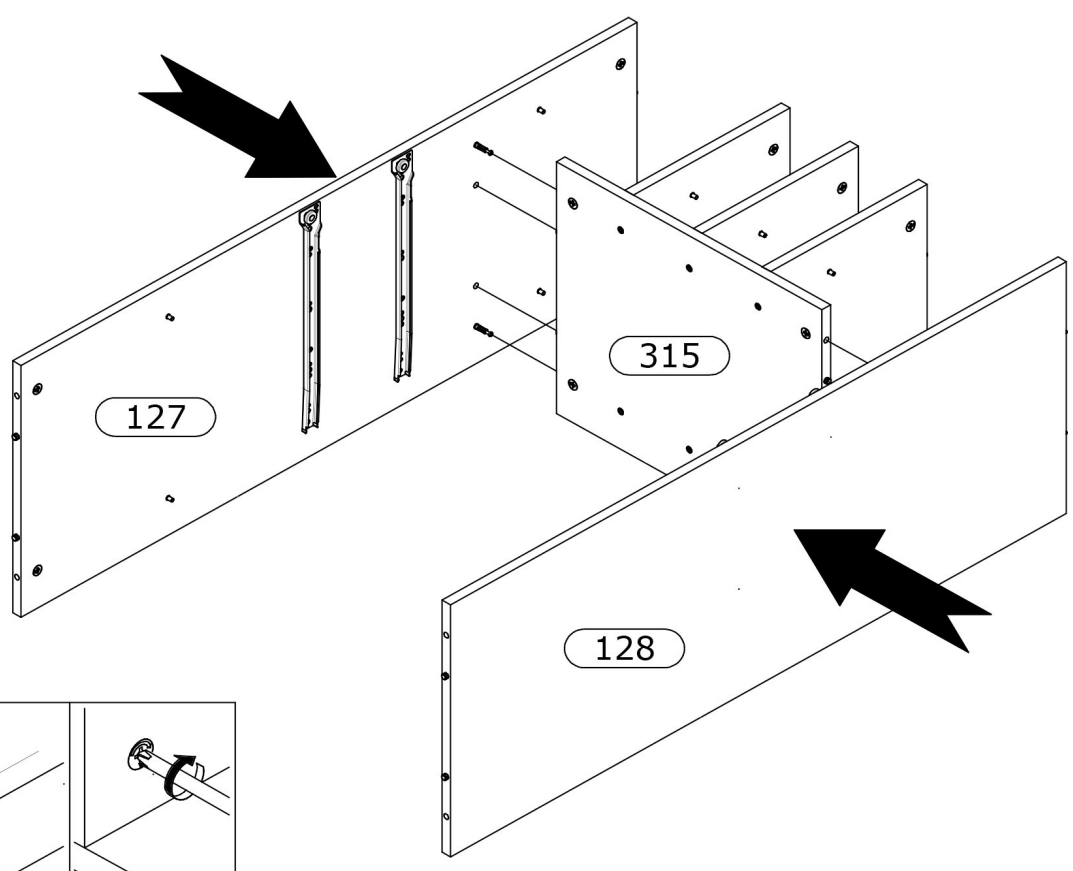
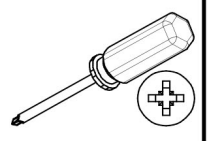

9

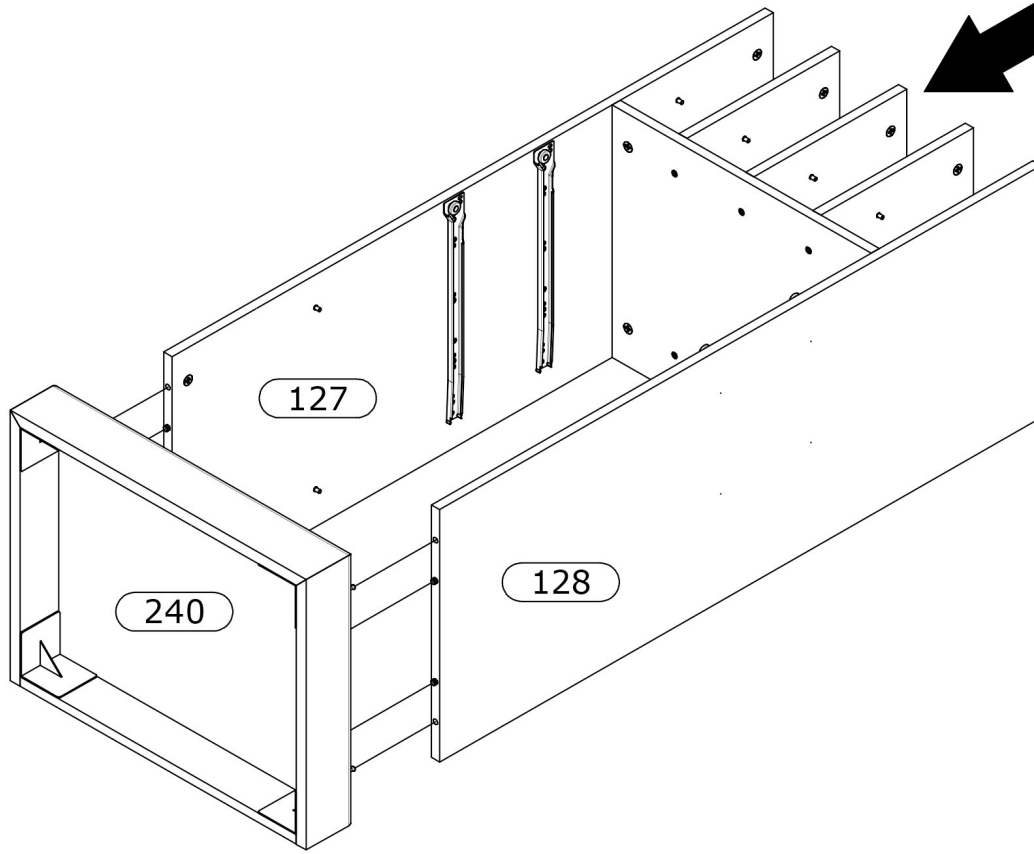

10

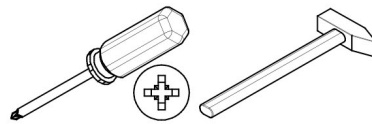
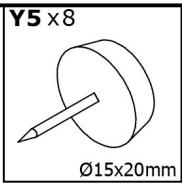

245

127

128

Y5



11

G1 x 28

H x 1

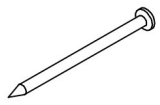

26mm

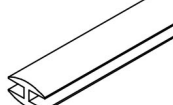

1125mm

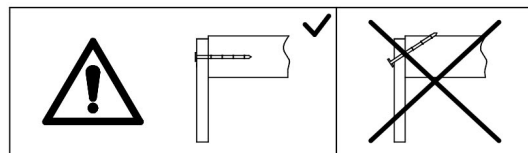
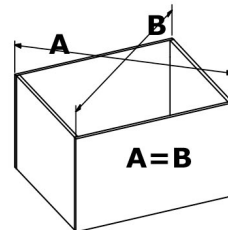
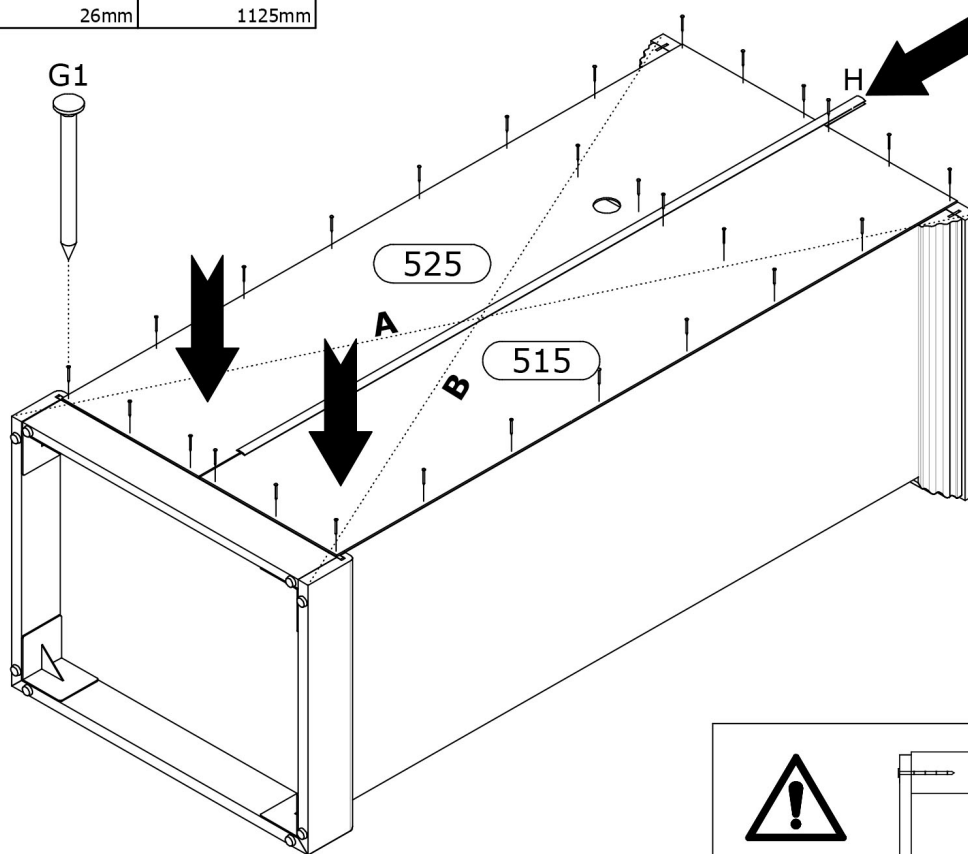
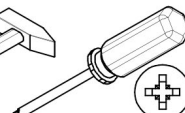
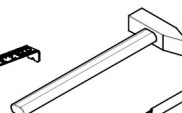
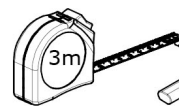

12

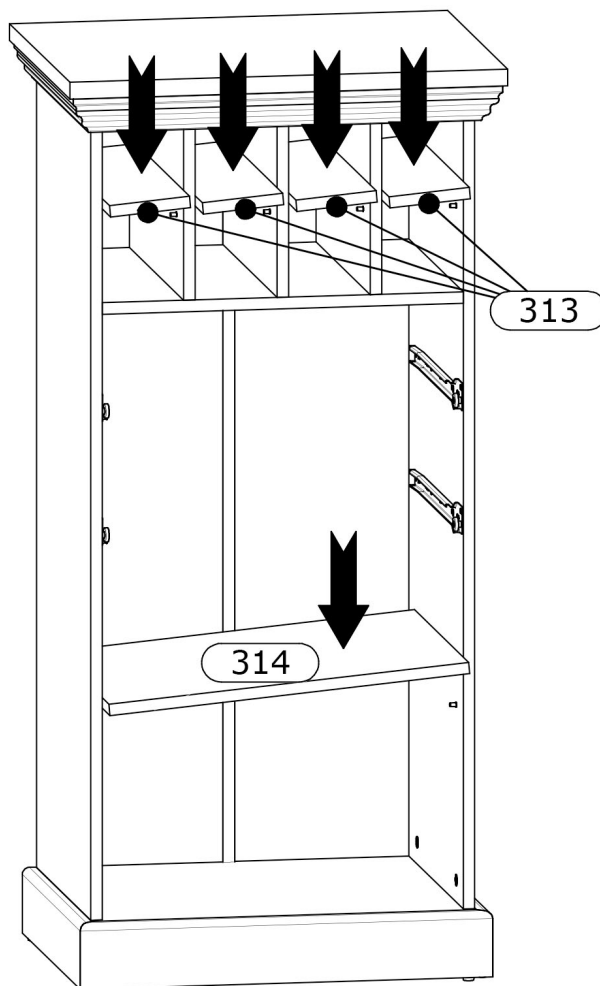

13

T4 x 1
75x28x16 mm

W2 x 2
Ø3,5x16mm

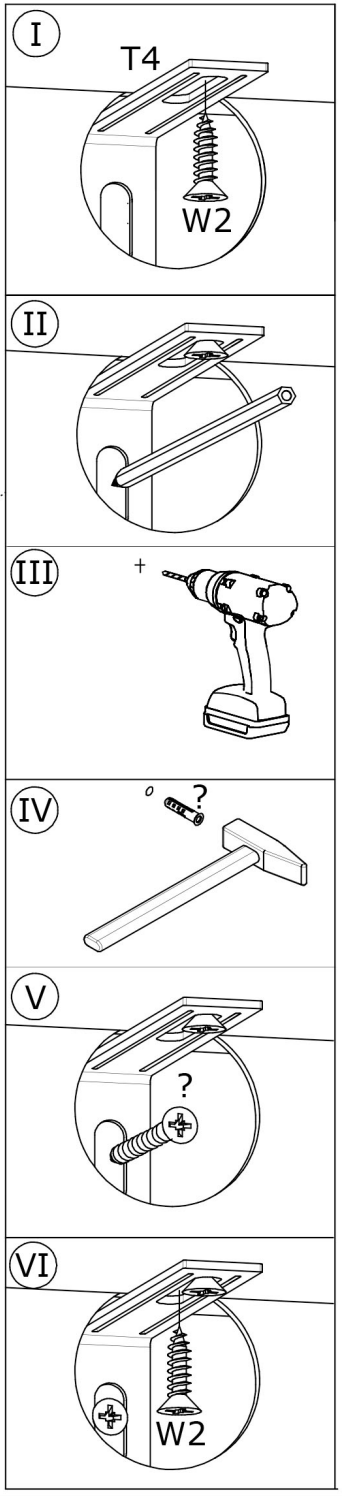
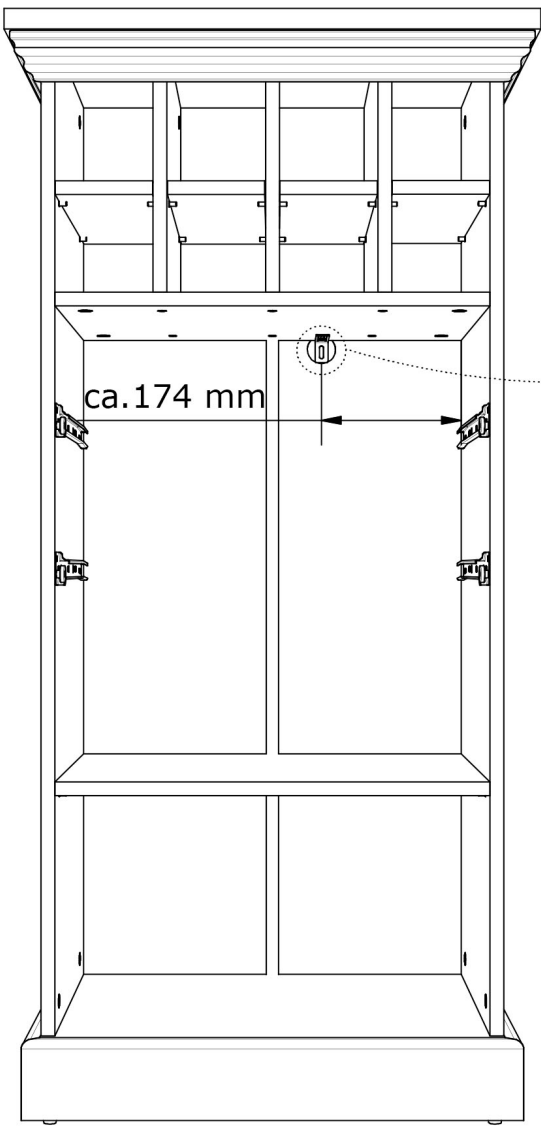
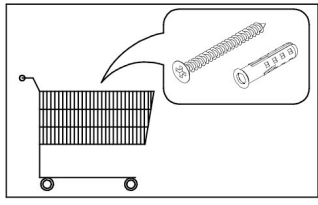
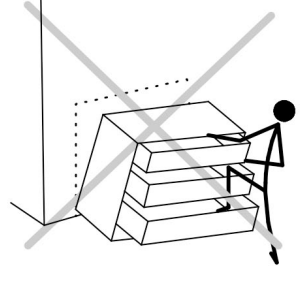
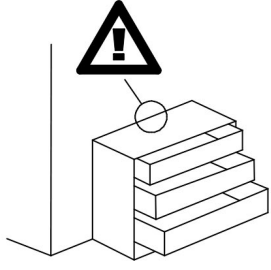
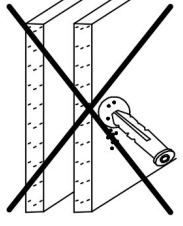
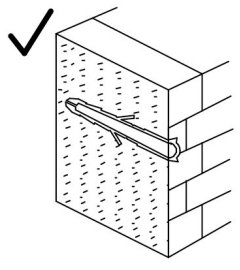
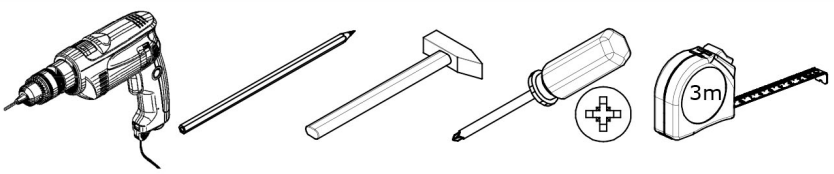

14

B1 x4

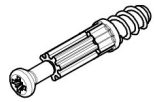

Ø5x38mm

Y1 x4



Ø8x1,5mm

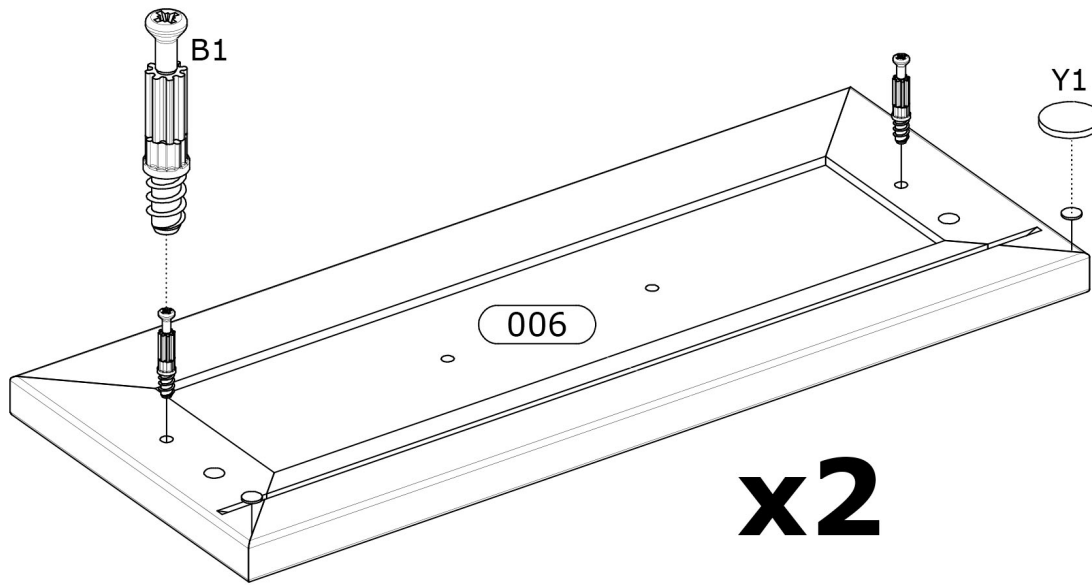
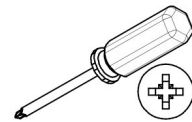

15

A1 x4

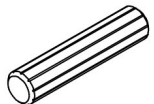

Ø8x35mm

C2 x4



Ø12x10mm

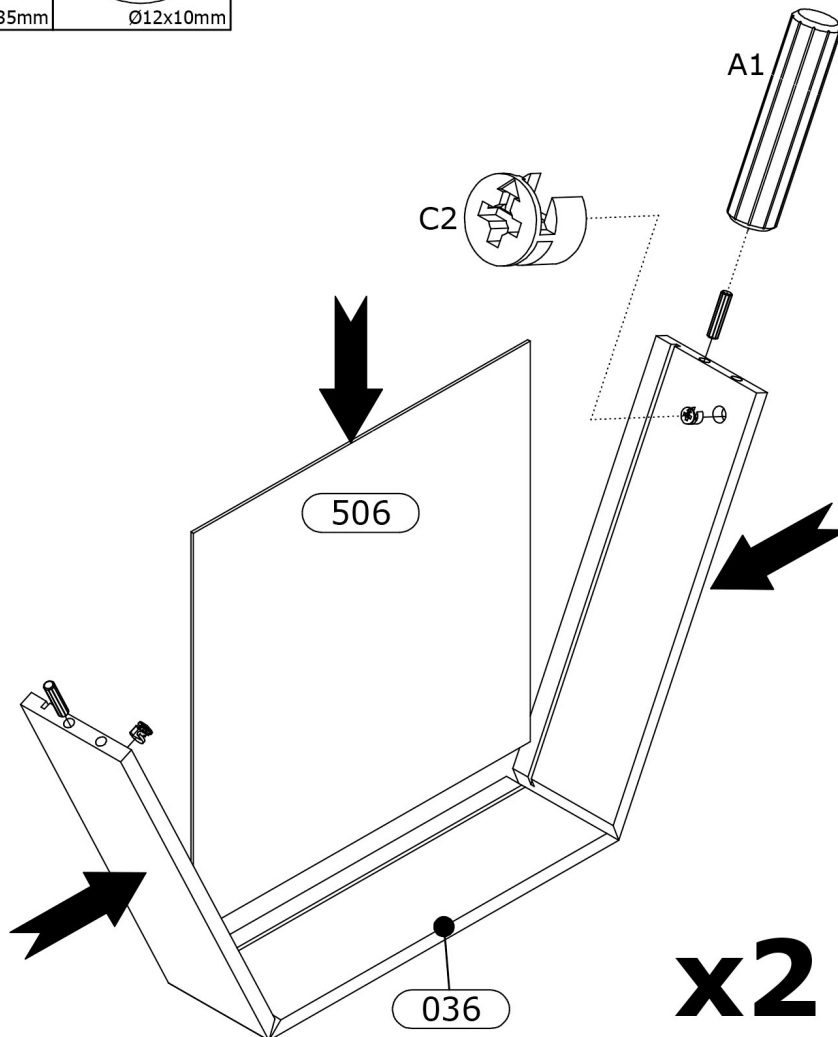
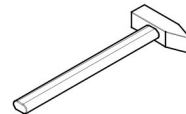

16

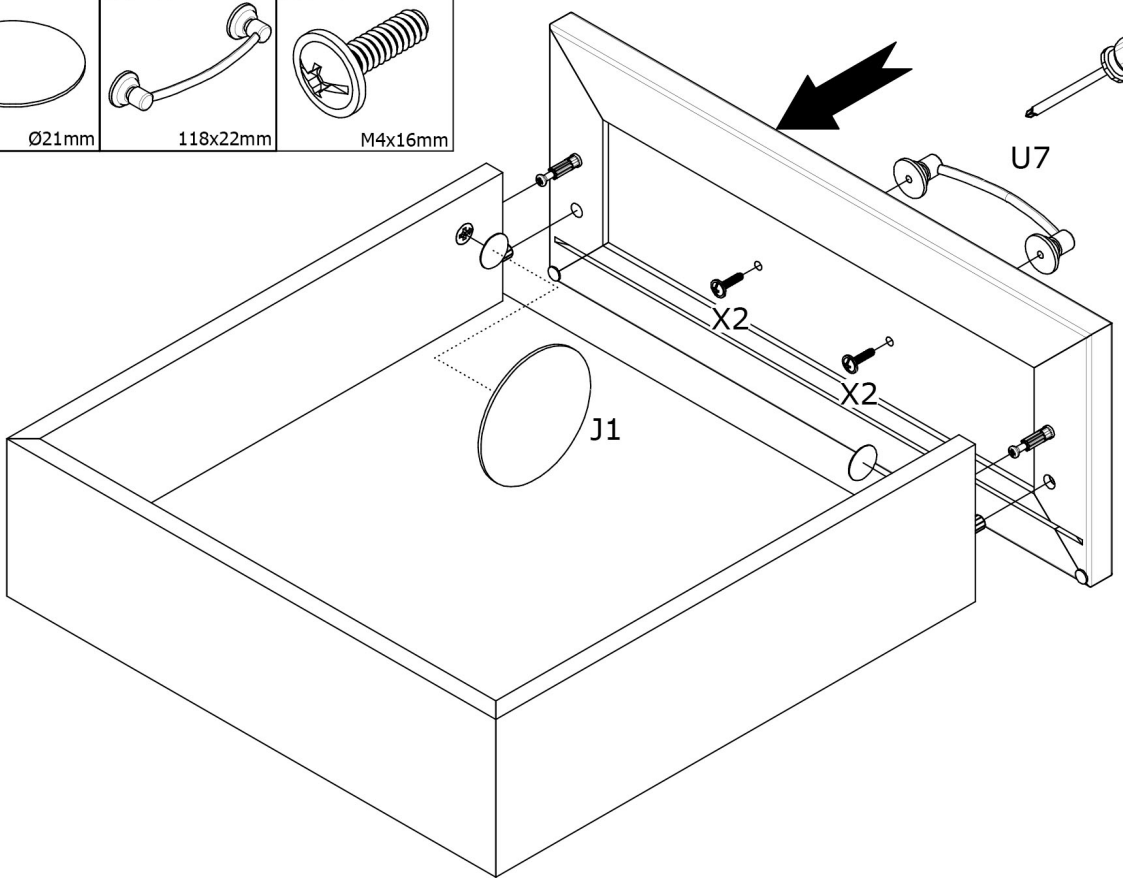
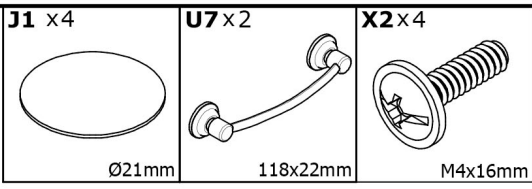

x2

17

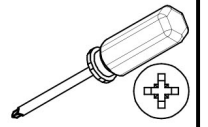
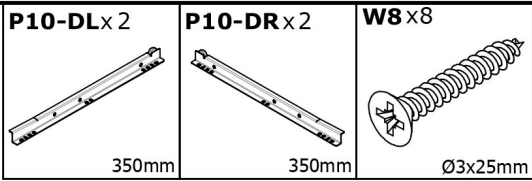

P10-DL

P10-DR

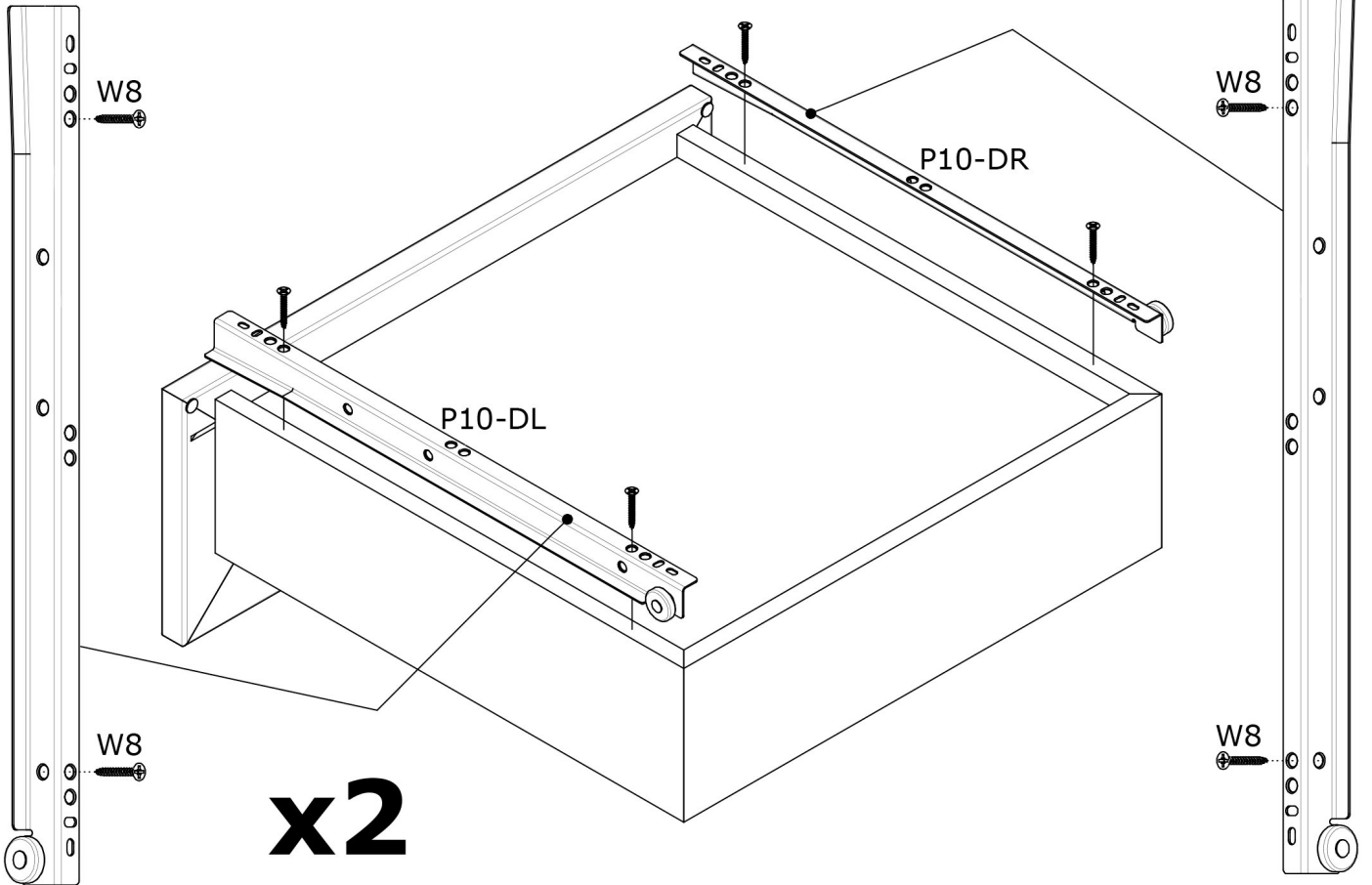

x2

18

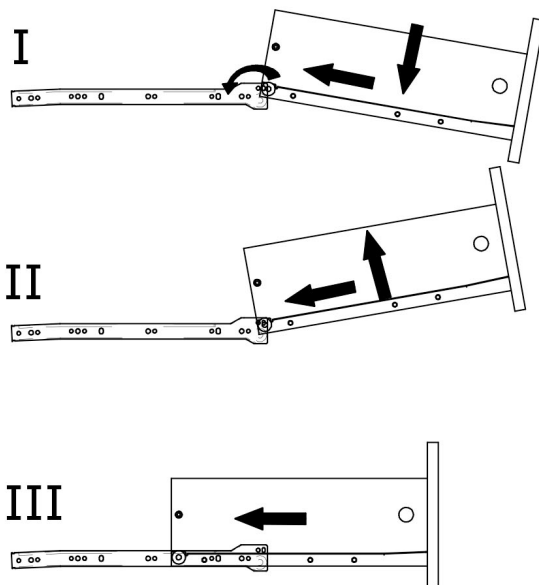
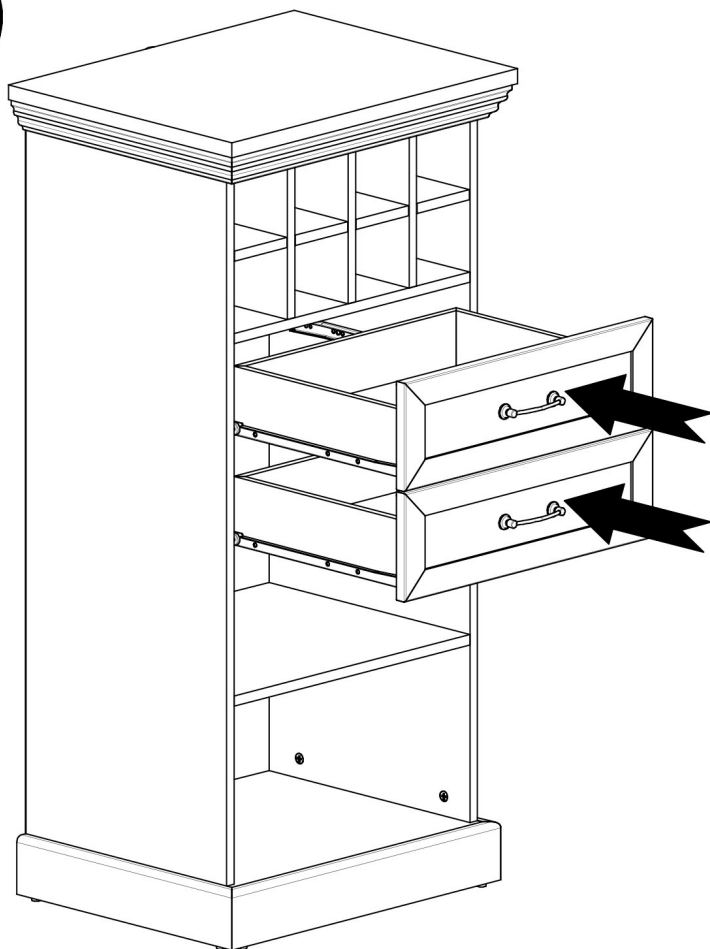

19

